

WR400

CIRCULAR SWIRL DIFFUSER
WITH FIXED BLADES

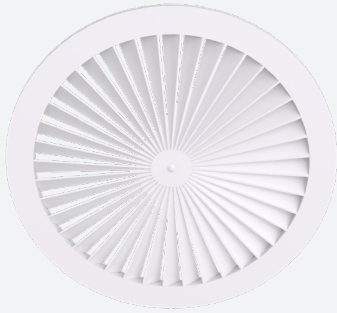

VARIANTS

WR400_S

The swirl diffuser type WR400 is equipped with fixed blades. It is designed for exposed duct mounting but can also be surface mounted. A high induction is obtained through the excellent swirl effect. The diffuser has a strong coanda effect over a wide temperature range (also at low flow rates) which makes it optimally suited for VAV applications.

Non-adjustable air pattern with fixed blades

High induction with strong coanda effect

Optimally suited for VAV applications

ACCESSORIES



WP400S

TECHNICAL INFORMATION

APPLICATION	Type	Supply or exhaust
	Airflow direction	Horizontal
CONSTRUCTION	Frontplate	Central screw fixing
	Nominal sizes	Ø160, 200, 250, 315
	Standard panel sizes	Ø448, 600mm
MATERIAL	Standard material	Frontplate: powder coated sheet steel Plenum: galvanised [275g/m ²] sheet steel
	Spigot plenum	PP/TPE spigot, Class D spigot with double lip seal
	Standard finishing	Powder coating RAL9010
	Product finishing options	Powder coating RAL of choice
	Insulation (optional)	Melamine 6mm
	Volume control (optional)	Galvanised perforated volume flow controller with manual operation
MOUNTING	Mounting options	Equipped with mounting eyes (Ø 7mm), mounting straps available upon request

QUICK SELECTION

Supply Q _v [m ³ /h]			
ØN [mm]	A [mm]	Lw	WR400 + WP400S
160	448	25 dB(A)	198
		35 dB(A)	270
200	448	25 dB(A)	248
		35 dB(A)	355
250	600	25 dB(A)	393
		35 dB(A)	547
315	600	25 dB(A)	484
		35 dB(A)	681

EFFECTIVE AIR DISCHARGE AREA

Supply A _k [m ²]	ØN [mm]			
	160	200	250	315
	0,028	0,028	0,056	0,056

PRODUCT KEY

CIRCULAR SWIRL DIFFUSER WITH FIXED BLADES

W	R	4	0	0	-	F	0	2	5	0	0	6	0	0
							Nominal size ØN (mm): 160, 200, 250, 315				Panel size ØA (mm): 448, 600			
							F: Coated							

PLENUM FOR CIRCULAR SWIRL DIFFUSER WITH FIXED BLADES

W	P	4	0	0	S	-	-	0	0	2	5	0	0	6	0	0
							Spigot ØD (mm): 160, 200, 250, 315				Plenum size (mm): 448, 600					
							0: Without mounting straps 1: With mounting straps									
							- : Without damper D : With damper									
							-: Non insulated plenum G: Insulated plenum									
							S: Side connection									

CIRCULAR SWIRL DIFFUSER WITH FIXED BLADES AND MOUNTED PLENUM

W	R	4	0	0	-	F	S	-	-	0	0	2	5	0	0	6	0	0
							Nominal size ØN (mm): 160, 200, 250, 315				Panel size ØA (mm): 448, 600							
							0: Without mounting straps 1: With mounting straps											
							- : Without damper D : With damper											
							-: Non insulated plenum G: Insulated plenum											
							S: Side connection											
							F: Coated											

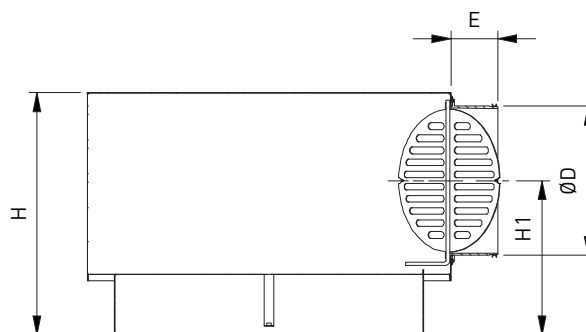
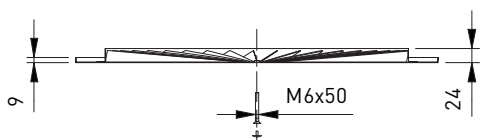
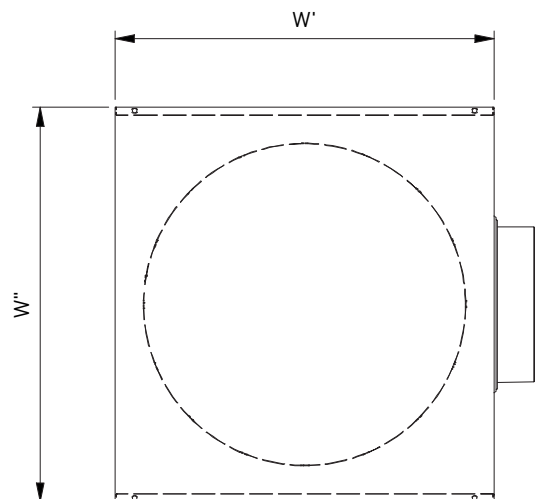
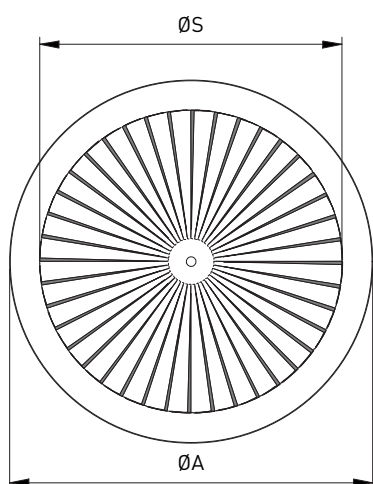

DIMENSIONS

ØN	ØA	ØB	ØD	E	H	H1	ØS	W' x W''
160	448	402	160	58	355	255	350	450 x 476
200	448	402	200	58	355	235	350	450 x 476
250	600	556	250	78	400	255	500	600 x 626
315	600	556	315	50	465	288	500	600 x 626

All dimensions in mm

